

Determining the wavelengths H_α , H_β and H_γ from the Balmer series of hydrogen

Objects of the experiments

- Observing the spectral lines of atomic hydrogen with a high-resolution grating.
- Measuring the wavelengths H_α , H_β and H_γ from the Balmer series.
- Determining the Rydberg constant R_∞ .

Principles

In the visible range, the emission spectrum of atomic hydrogen has the lines H_α , H_β , and H_γ . These lines belong to a complete series which extends into the ultra-violet range. In 1885, *Balmer* stated the following empirical formula for the frequencies of this series:

$$\nu = R_\infty \cdot \left(\frac{1}{2^2} - \frac{1}{m^2} \right), \quad m: 3, 4, 5, \dots \quad (I)$$

$R_\infty = 3.2899 \cdot 10^{15} \text{ s}^{-1}$: Rydberg constant.

Later the Balmer formula was explained in the framework of the Bohr atom model (see Fig. 1).

In the experiment, the emission spectrum is excited by means of a Balmer lamp which is filled with water vapour. The water molecules are decomposed by electric discharge into excited atomic hydrogen and a hydroxyl group. The wavelengths H_α , H_β and H_γ are determined with a high-resolution grating. In the first order of the grating, the relation between the wavelength λ and the angle of observation ϑ is

$$\lambda = d \cdot \sin \vartheta \quad (II)$$

d : grating constant

The measured values are compared with the frequencies calculated according to the Balmer formula (I).

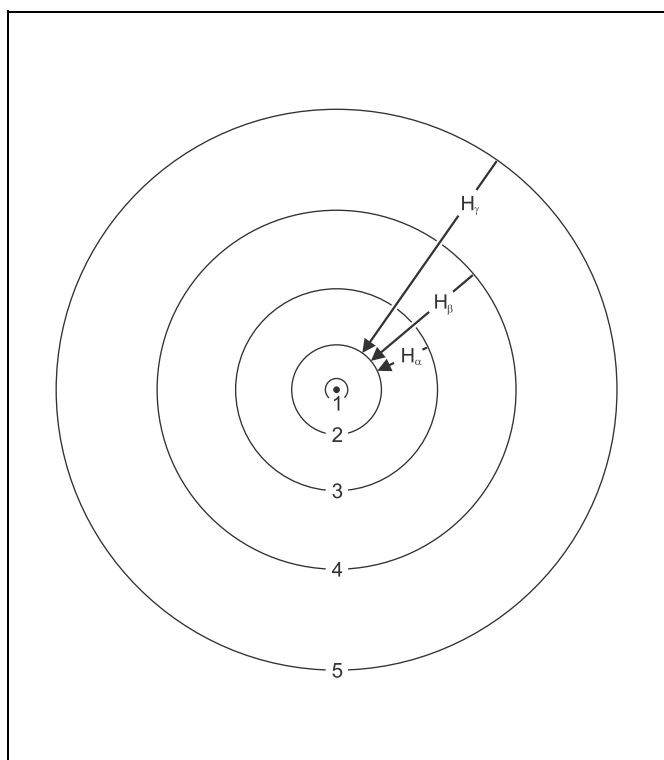

Fig. 1 The Bohr atom model of hydrogen with transitions from the Balmer series (schematic diagram).

Apparatus

1 Balmer lamp	451 13
1 power supply unit for Balmer lamps	451 14
1 copy of a Rowland grating	471 23
1 holder with spring clips	460 22
1 lens, $f = + 50$ mm	460 02
1 lens, $f = + 100$ mm	460 03
1 adjustable slit	460 14
1 translucent screen	441 53
1 small optical bench	460 43
1 stand base, V-shape, 28 cm	300 01
6 Leybold multiclips	301 01
1 steel tape measure, 2 m	311 77

Setup

Remark:

The spectral lines can only be observed in a completely darkened room.

The experimental setup is illustrated in Figs. 2 and 3.

Mounting:

- If necessary, mount the Balmer lamp in the holder as explained in the instruction sheet.
- Set the small optical bench up, and fasten the Leybold multiclips as shown in Fig. 2. The second multiclip has to be rotated by 180°.
- Mount the holder with the Balmer lamp on the optical bench, connect the power supply unit to the mains, and switch it on.
- Mount the two lenses, the adjustable slit and the holder with spring clips, and align them in height.
- Mount the translucent screen as shown in Fig. 3.

Fine adjustment:

- Align the Balmer lamp with the optical axis by turning the holder in the Leybold multiclip and by vertical displacement.
- Displace the lens, $f = 50$ mm, parallel and orthogonally to the optical axis until the Balmer lamp is sharply imaged on the adjustable slit.
- Image the slit on the translucent screen sharply by displacing the lens, $f = 100$ mm.

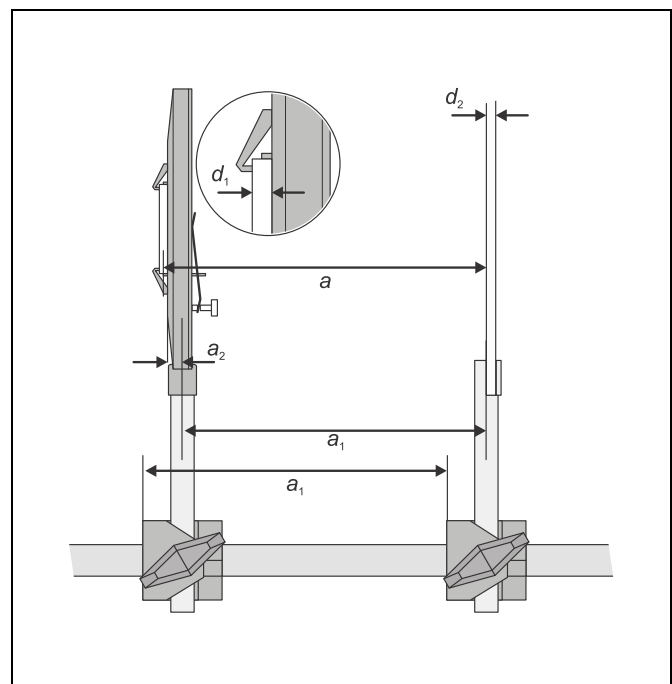
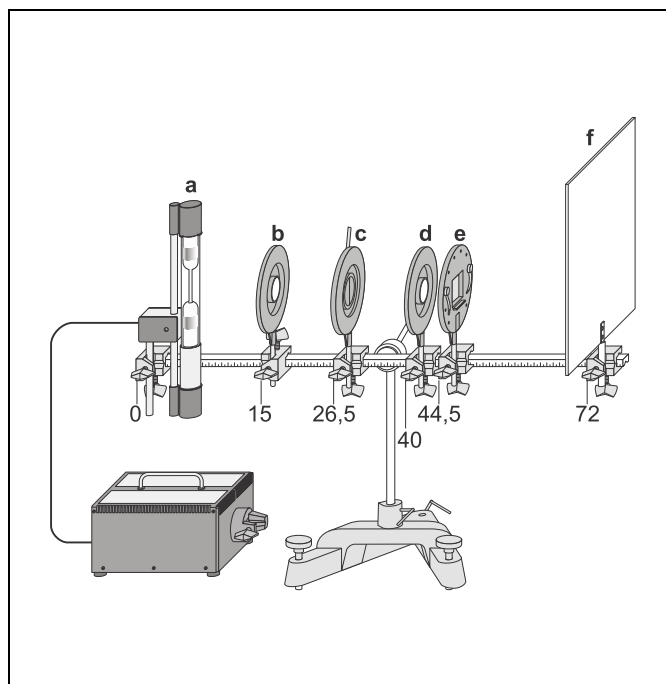

Fig. 2 Experimental setup for studying the Balmer series of atomic hydrogen (the figures indicate the positions of the left edges of the multiclips on the optical bench).

- a Balmer lamp
- b imaging lens $f = 50$ mm
- c adjustable slit
- d imaging lens $f = 100$ mm
- e grating
- f screen

Fig. 3 Detail drawing with Rowland grating and translucent screen

Safety note

The power supply unit generates dangerous contact voltages accessible at the contacts of the holder as long as the Balmer lamp has not been mounted.

- Do not connect the power supply unit as long as the Balmer lamp has not yet been mounted.

Carrying out the experiment

- Move the copy of a Rowland grating into the ray path.
- Darken the experiment room completely, and observe the translucent screen in transmission.
- Narrow the adjustable slit until separate lines are visible on the screen.
- If necessary, block unwanted light from the Balmer lamp with a masking plate made from cardboard.
- Mark the positions of the lines and of the zeroth order on the screen.
- Measure the distances b between the lines and the zeroth order on the screen.
- Determine the distance a between the Rowland grating and the translucent screen (see Fig. 3).

Measuring example

Distance of the grating a :

- multiclamp 1 – multiclamp 2: $a_1 = 275 \text{ mm}$
- middle of handle – edge of holder: $a_2 = 5 \text{ mm}$
- Rowland grating: $d_1 = 2.5 \text{ mm}$
- translucent screen: $d_2 = 3 \text{ mm}$

Distances of the lines:

Table 1: Distances b between the lines and the zeroth order (grating constant $g = 600 \text{ mm}^{-1}$)

Colour	$\frac{b}{\text{mm}}$	
	left	right
red	121	123
tourquoise	89	87
blue	78	76

Evaluation

Grating constant: $d = \frac{1}{g} = 1.67 \mu\text{m}$

Distance of the grating (see Fig. 3):

$$a = a_1 + a_2 + \frac{d_1}{2} + d_2 = 284 \text{ mm}$$

From Fig. 4 $\sin \vartheta = \frac{b}{\sqrt{a^2 + b^2}}$ follows.

Together with (II) this gives $\lambda = d \cdot \frac{b}{\sqrt{a^2 + b^2}}$ or

$$\nu = \frac{c}{d} \cdot \frac{\sqrt{a^2 + b^2}}{b} \text{ respectively.}$$

c : velocity of light in vacuum

Table 2: wavelengths and frequencies of the observed lines.

Colour	line	$\frac{\lambda}{\text{nm}}$	$\frac{\nu}{\text{THz}}$	$\frac{1}{4} - \frac{1}{m^2}$
red	H_α	658	456	0.1389
tourquoise	H_β	493	608	0.1875
blue	H_γ	436	688	0.2100

In Table 2, the wavelengths and frequencies of the lines H_α , H_β and H_γ as determined in the experiment are listed. Fig. 5 is a plot of the frequencies as a function of the term $\frac{1}{4} - \frac{1}{m^2}$. The slope of the straight line through the origin drawn in the graph is $R = 3.27 \cdot 10^{15} \text{ s}^{-1}$. This value is in excellent agreement with the value of the Rydberg constant quoted in the literature (see above).

Results

The frequencies of the Balmer series of hydrogen are given by the Balmer formula, which follows immediately from the Bohr atom model.

Fig. 4 First order diffraction at a grating.

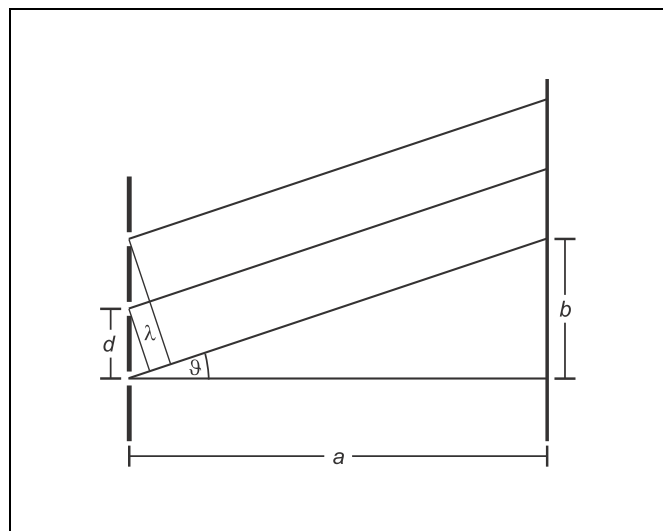

Fig. 5 Frequencies ν as a function of $\frac{1}{4} - \frac{1}{m^2}$

